

Student Name \_\_\_\_\_



**Geometry**

**Test Booklet**

***Practice Test***

**Secure Test Materials – Do Not Copy**

This test booklet is secure. It may not be copied or duplicated in any way.  
This test booklet (used or unused) must be returned at the completion of  
testing as directed.

# Unit 1

**Directions:**

Today, you will be taking Unit 1 of the Geometry Practice Test.

Read each question carefully. Some questions will ask you to choose one correct answer, while others will ask you to choose more than one correct answer. Mark your answers by filling in the circles in your answer document for the answers you choose.

Do not make any stray marks in the answer document. If you need to change an answer in your answer document, be sure to erase your first answer completely.

**Calculator Directions:**

In the first section of this unit, you may not use a calculator. You will not be allowed to return to the non-calculator section of the test after you have started the calculator section of the test.

If you do not know the answer to a question, skip it and go on. If you finish the non-calculator section of Unit 1 early, you may review your answers and any questions you may have skipped in the non-calculator section ONLY.

**Do NOT go on to the calculator section in Unit 1 until directed to do so.**

**Directions for Completing the Answer Grids**

1. Work the problem and find an answer.
2. Write your answer in the boxes at the top of the grid.
  - Print only one digit or symbol in each box. You may not need all the boxes to enter an answer, but do not leave a blank box in the middle of an answer.
3. Under each box in which you wrote your answer, fill in the bubble that matches the number or symbol you wrote above.
  - Fill in one and **ONLY** one bubble for each box. Do not fill in a bubble under an unused box.
  - Fill in each bubble by making a solid mark that completely fills the circle.
  - Fractions cannot be entered into an Answer Grid and will not be scored. Enter fractions as decimals.
4. See below for examples on how to correctly complete an answer grid.

To answer  $-3$  in a question, fill in the answer grid as follows:

-	3					
<input checked="" type="radio"/>	<input type="radio"/>	<input type="radio"/>	<input type="radio"/>	<input type="radio"/>	<input type="radio"/>	<input type="radio"/>
<input type="radio"/>	<input type="radio"/>	<input type="radio"/>	<input type="radio"/>	<input type="radio"/>	<input type="radio"/>	<input type="radio"/>
<input type="radio"/>	<input type="radio"/>	<input type="radio"/>	<input type="radio"/>	<input type="radio"/>	<input type="radio"/>	<input type="radio"/>
<input type="radio"/>	<input type="radio"/>	<input type="radio"/>	<input type="radio"/>	<input type="radio"/>	<input type="radio"/>	<input type="radio"/>
<input checked="" type="radio"/>	<input type="radio"/>	<input type="radio"/>	<input type="radio"/>	<input type="radio"/>	<input type="radio"/>	<input type="radio"/>
<input type="radio"/>	<input type="radio"/>	<input type="radio"/>	<input type="radio"/>	<input type="radio"/>	<input type="radio"/>	<input type="radio"/>
<input type="radio"/>	<input type="radio"/>	<input type="radio"/>	<input type="radio"/>	<input type="radio"/>	<input type="radio"/>	<input type="radio"/>
<input type="radio"/>	<input type="radio"/>	<input type="radio"/>	<input type="radio"/>	<input type="radio"/>	<input type="radio"/>	<input type="radio"/>
<input type="radio"/>	<input type="radio"/>	<input type="radio"/>	<input type="radio"/>	<input type="radio"/>	<input type="radio"/>	<input type="radio"/>
<input type="radio"/>	<input type="radio"/>	<input type="radio"/>	<input type="radio"/>	<input type="radio"/>	<input type="radio"/>	<input type="radio"/>
<input type="radio"/>	<input type="radio"/>	<input type="radio"/>	<input type="radio"/>	<input type="radio"/>	<input type="radio"/>	<input type="radio"/>
<input type="radio"/>	<input type="radio"/>	<input type="radio"/>	<input type="radio"/>	<input type="radio"/>	<input type="radio"/>	<input type="radio"/>
<input type="radio"/>	<input type="radio"/>	<input type="radio"/>	<input type="radio"/>	<input type="radio"/>	<input type="radio"/>	<input type="radio"/>

To answer  $.75$  in a question, fill in the answer grid as follows:

.	7	5				
<input type="radio"/>	<input checked="" type="radio"/>	<input type="radio"/>	<input type="radio"/>	<input type="radio"/>	<input type="radio"/>	<input type="radio"/>
<input type="radio"/>	<input type="radio"/>	<input type="radio"/>	<input type="radio"/>	<input type="radio"/>	<input type="radio"/>	<input type="radio"/>
<input type="radio"/>	<input type="radio"/>	<input type="radio"/>	<input type="radio"/>	<input type="radio"/>	<input type="radio"/>	<input type="radio"/>
<input type="radio"/>	<input type="radio"/>	<input type="radio"/>	<input type="radio"/>	<input type="radio"/>	<input type="radio"/>	<input type="radio"/>
<input type="radio"/>	<input type="radio"/>	<input type="radio"/>	<input type="radio"/>	<input type="radio"/>	<input type="radio"/>	<input type="radio"/>
<input type="radio"/>	<input type="radio"/>	<input type="radio"/>	<input type="radio"/>	<input type="radio"/>	<input type="radio"/>	<input type="radio"/>
<input type="radio"/>	<input type="radio"/>	<input type="radio"/>	<input type="radio"/>	<input type="radio"/>	<input type="radio"/>	<input type="radio"/>
<input type="radio"/>	<input type="radio"/>	<input type="radio"/>	<input type="radio"/>	<input type="radio"/>	<input type="radio"/>	<input type="radio"/>
<input type="radio"/>	<input type="radio"/>	<input type="radio"/>	<input type="radio"/>	<input type="radio"/>	<input type="radio"/>	<input type="radio"/>
<input type="radio"/>	<input type="radio"/>	<input type="radio"/>	<input type="radio"/>	<input type="radio"/>	<input type="radio"/>	<input type="radio"/>
<input type="radio"/>	<input type="radio"/>	<input type="radio"/>	<input type="radio"/>	<input type="radio"/>	<input type="radio"/>	<input type="radio"/>
<input type="radio"/>	<input type="radio"/>	<input type="radio"/>	<input type="radio"/>	<input type="radio"/>	<input type="radio"/>	<input type="radio"/>
<input type="radio"/>	<input type="radio"/>	<input type="radio"/>	<input type="radio"/>	<input type="radio"/>	<input type="radio"/>	<input type="radio"/>
<input type="radio"/>	<input type="radio"/>	<input type="radio"/>	<input type="radio"/>	<input type="radio"/>	<input type="radio"/>	<input type="radio"/>

**GO ON TO NEXT PAGE**

# Unit 1 - Section 1 (Non-Calculator)

This unit has two sections: a non-calculator and a calculator section.

You will now take the first section of this unit in which you may not use a calculator. You will not be allowed to return to the non-calculator section of the test after you have started the calculator section. You will need to finish both sections within the allotted testing time.

**Once you finish the non-calculator section, read the directions in your test booklet on how to continue.**

1. The figure shows  $\triangle ABC \sim \triangle DEF$  with side lengths as indicated.

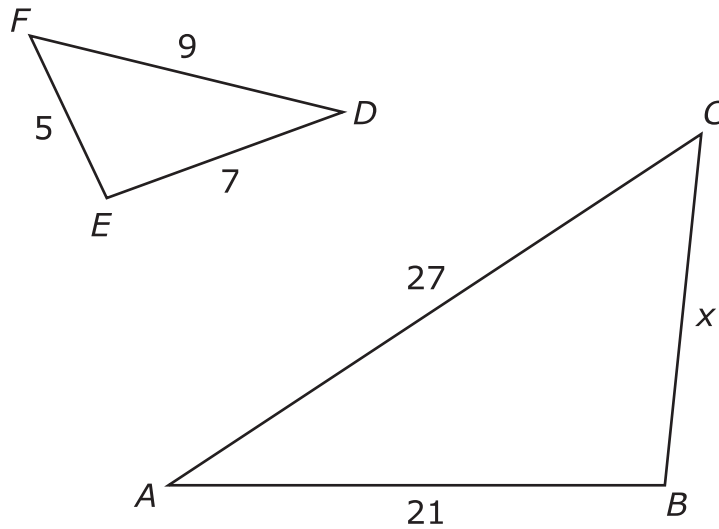

What is the value of  $x$ ?

Enter your answer in the box.

2. The figure shows two perpendicular lines  $s$  and  $r$  intersecting at point  $P$  in the interior of a trapezoid. Line  $r$  is parallel to the bases and bisects both legs of the trapezoid. Line  $s$  bisects both bases of the trapezoid.

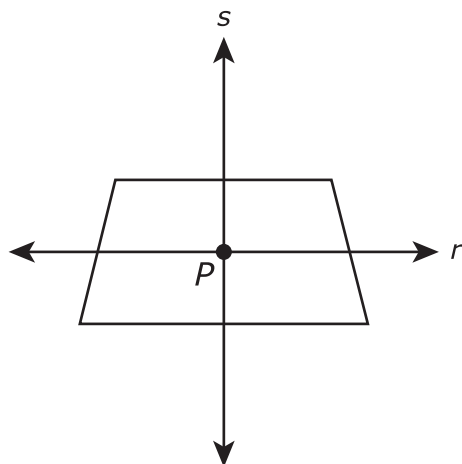

Which transformation will always carry the figure onto itself?

Select **all** that apply.

- A. a reflection across line  $r$
- B. a reflection across line  $s$
- C. a rotation of  $90^\circ$  clockwise about point  $P$
- D. a rotation of  $180^\circ$  clockwise about point  $P$
- E. a rotation of  $270^\circ$  clockwise about point  $P$

3. The circle with center  $F$  is divided into sectors. In circle  $F$ ,  $\overline{EB}$  is a diameter. The length of  $\overline{FB}$  is 3 units.

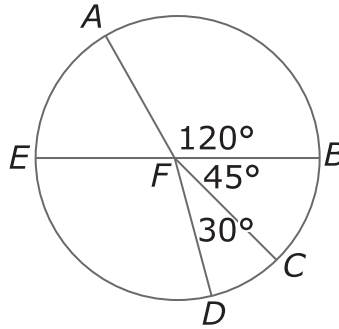

Select the correct expression that represents the arc length of arc  $\widehat{AED}$ .

- A.  $\pi$
  - B.  $\frac{11\pi}{4}$
  - C.  $\frac{13\pi}{4}$
  - D.  $\frac{7\pi}{4}$
4. A rectangle will be rotated  $360^\circ$  about a line which contains the point of intersection of its diagonals and is parallel to a side. What three-dimensional shape will be created as a result of the rotation?
- A. a cube
  - B. a rectangular prism
  - C. a cylinder
  - D. a sphere



5. Line segment  $JK$  in the  $xy$ -coordinate plane has endpoints with coordinates  $(-4, 11)$  and  $(8, -1)$ . What are **two** possible locations for point  $M$  so that  $M$  divides  $\overline{JK}$  into two parts with lengths in a ratio of 1:3 ?

Indicate **both** locations.

- A.  $(-2, 9)$
- B.  $(-1, 8)$
- C.  $(0, 7)$
- D.  $(1, 6)$
- E.  $(3, 4)$
- F.  $(4, 3)$
- G.  $(5, 2)$
- H.  $(6, 1)$

Use the information provided to answer Part A and Part B for question 6.

The equation  $x^2 + y^2 - 4x + 2y = b$  describes a circle.

**6. Part A**

Determine the  $y$ -coordinate of the center of the circle.

Enter your answer in the box.

**Part B**

The radius of the circle is 7 units. What is the value of  $b$  in the equation?

Enter your answer in the box.

## Mathematics

---

7. In the  $xy$ -coordinate plane,  $\triangle ABC$  has vertices at  $A(1, -2)$ ,  $B(1, 0.5)$ , and  $C(2, 1)$  and  $\triangle DEF$  has vertices at  $D(4, -3)$ ,  $E(4, 2)$ , and  $F(6, 3)$ .

The triangles are similar because  $\triangle DEF$  is the image of  $\triangle ABC$  under a dilation. What is the center and the scale factor for this dilation?

Select the **two** true statements.

- A. The center of dilation is at  $(-2, -1)$ .
- B. The center of dilation is at  $(-1, -2)$ .
- C. The center of dilation is at  $(0, 0)$ .
- D. The scale factor is  $\frac{1}{2}$ .
- E. The scale factor is 2.
- F. The scale factor is 4.





**You have come to the end of the non-calculator section in Unit 1 of the test.**

- **If you have time, review your answers in the non-calculator section ONLY. You will not be allowed to return to the non-calculator section once you have received your calculator.**
- **Then, raise your hand to receive your calculator before going on to the calculator section.**







# Unit 1 - Section 2 (Calculator)

Once you have received your calculator, continue with the calculator section.



8. The figure shows  $\triangle ABC$  inscribed in circle  $D$ .

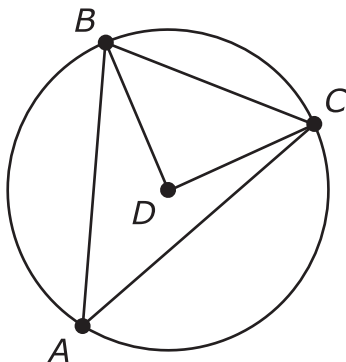

If  $m\angle CBD = 44^\circ$ , find  $m\angle BAC$ .

Enter your answer in the box.

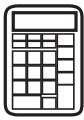

9. The figure shows lines  $r$ ,  $n$ , and  $p$  intersecting to form angles numbered 1, 2, 3, 4, 5, and 6. All three lines lie in the same plane.

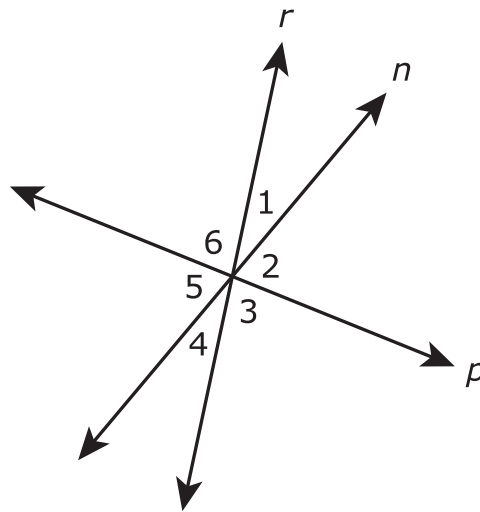

not to scale

Based on the figure, which of the individual statements would provide enough information to conclude that line  $r$  is perpendicular to line  $p$ ?

Select **all** that apply.

- A.  $m\angle 2 = 90^\circ$
- B.  $m\angle 6 = 90^\circ$
- C.  $m\angle 3 = m\angle 6$
- D.  $m\angle 1 + m\angle 6 = 90^\circ$
- E.  $m\angle 3 + m\angle 4 = 90^\circ$
- F.  $m\angle 4 + m\angle 5 = 90^\circ$



10.

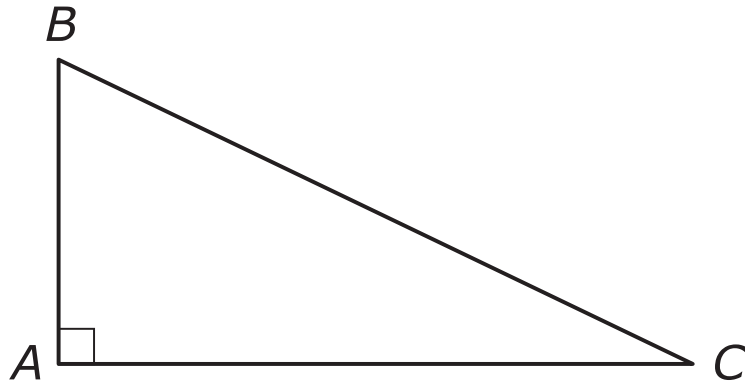

In right triangle  $ABC$ ,  $m\angle B \neq m\angle C$ . Let  $\sin B = r$  and  $\cos B = s$ . What is  $\sin C - \cos C$ ?

- A.  $r + s$
- B.  $r - s$
- C.  $s - r$
- D.  $\frac{r}{s}$





11. Triangle  $ABC$  is shown in the  $xy$ -coordinate plane.

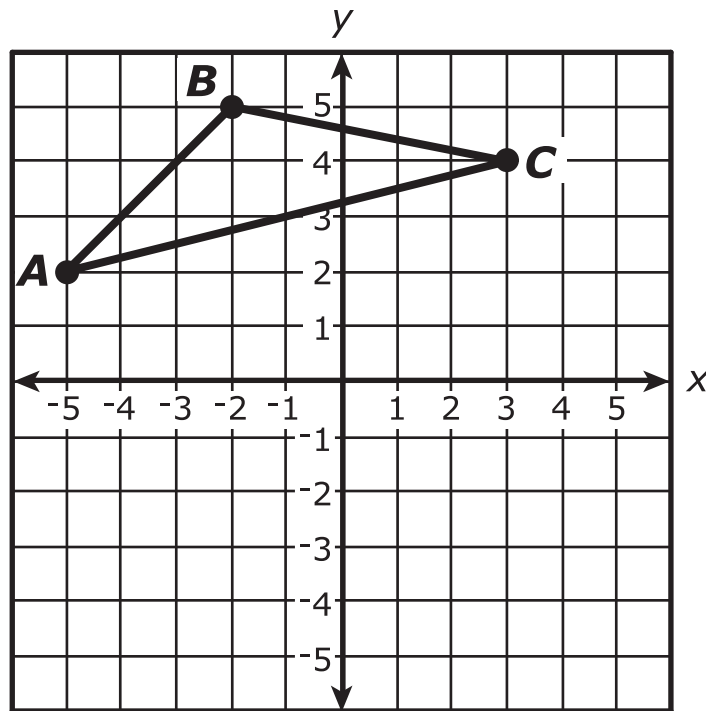

The triangle will be rotated  $180^\circ$  clockwise around the point  $(3, 4)$  to create  $\triangle A'B'C'$ . Which characteristics of  $\triangle A'B'C'$  will be the same for the corresponding characteristic of  $\triangle ABC$ ?

Select **all** that apply.

- A. the coordinates of  $A'$
- B. the coordinates of  $B'$
- C. the perimeter of  $\triangle A'B'C'$
- D. the area of  $\triangle A'B'C'$
- E. the measure of  $\angle B'$
- F. the length of segment  $A'B'$

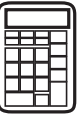

12. The figure shows two semicircles with centers  $P$  and  $M$ . The semicircles are tangent to each other at point  $B$ , and  $\overline{DE}$  is tangent to both semicircles at  $F$  and  $E$ .

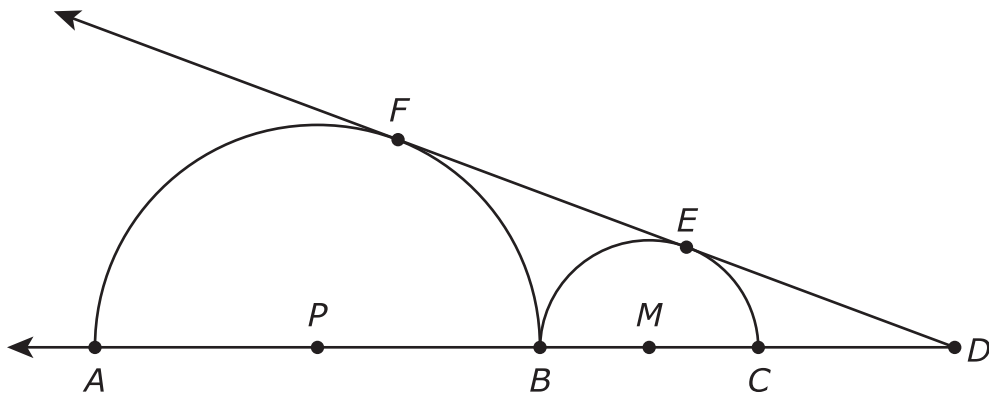

If  $PB = BC = 6$ , what is  $ED$ ?

- A. 6
- B.  $\sqrt{48}$
- C. 8
- D.  $\sqrt{72}$

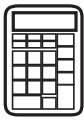

13. The figure shows line  $AC$  and line  $PQ$  intersecting at point  $B$ . Lines  $A'C'$  and  $P'Q'$  will be the images of lines  $AC$  and  $PQ$ , respectively, under a dilation with center  $P$  and scale factor 2.

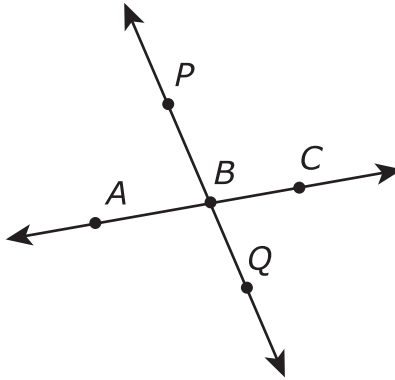

Which statement about the image of lines  $AC$  and  $PQ$  would be true under the dilation?

- A. Line  $A'C'$  will be parallel to line  $AC$ , and line  $P'Q'$  will be parallel to line  $PQ$ .
  - B. Line  $A'C'$  will be parallel to line  $AC$ , and line  $P'Q'$  will be the same line as line  $PQ$ .
  - C. Line  $A'C'$  will be perpendicular to line  $AC$ , and line  $P'Q'$  will be parallel to line  $PQ$ .
  - D. Line  $A'C'$  will be perpendicular to line  $AC$ , and line  $P'Q'$  will be the same line as line  $PQ$ .
14. The equation  $x^2 - 8x + y^2 = 9$  defines a circle in the  $xy$ -coordinate plane. What is the radius of the circle?

Enter your answer in the box.

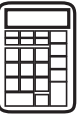

15. The table shows the approximate measurements of the Great Pyramid of Giza in Egypt and the Pyramid of Kukulcan in Mexico.

Pyramid	Height (meters)	Area of Base (square meters)
Great Pyramid of Giza	147	52,900
Pyramid of Kukulcan	30	3,025

Approximately what is the difference between the volume of the Great Pyramid of Giza and the volume of the Pyramid of Kukulcan?

- A. 1,945,000 cubic meters
- B. 2,562,000 cubic meters
- C. 5,835,000 cubic meters
- D. 7,686,000 cubic meters

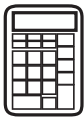

16. In the  $xy$ -coordinate plane,  $\triangle ABC$  has vertices  $A(-4, 6)$ ,  $B(2, 6)$ , and  $C(2, 2)$ .  $\triangle DEF$  is shown in the plane.

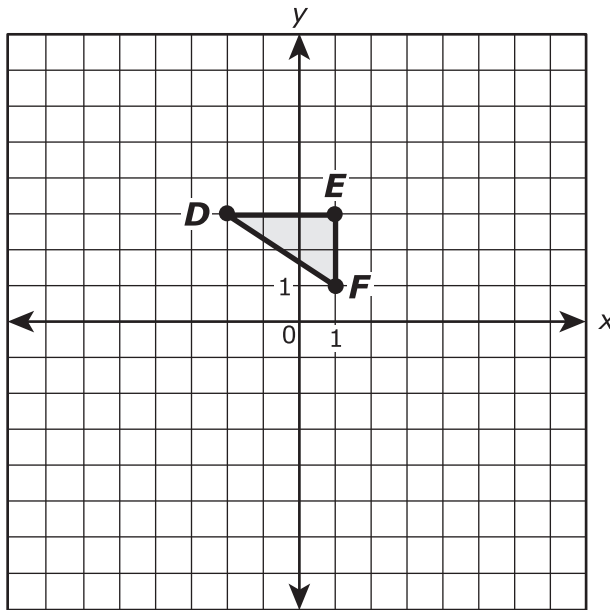

What is the scale factor and the center of dilation that maps  $\triangle ABC$  to  $\triangle DEF$ ?

- A.** The scale factor is 2, and the center of dilation is point  $B$ .
- B.** The scale factor is 2, and the center of dilation is the origin.
- C.** The scale factor is  $\frac{1}{2}$ , and the center of dilation is point  $B$ .
- D.** The scale factor is  $\frac{1}{2}$ , and the center of dilation is the origin.

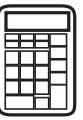

17. An archaeological team is excavating artifacts from a sunken merchant vessel on the ocean floor. To assist the team, a robotic probe is used remotely. The probe travels approximately 3,900 meters at an angle of depression of 67.4 degrees from the team's ship on the ocean surface down to the sunken vessel on the ocean floor. The figure shows a representation of the team's ship and the probe.

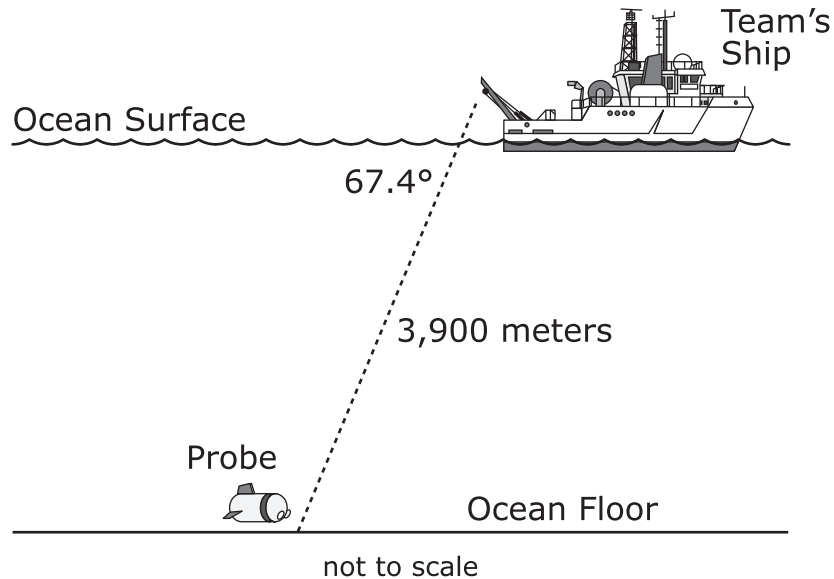

How many meters below the surface of the ocean will the probe be when it reaches the ocean floor?

Give your answer to the nearest hundred meters. Enter your answer in the box.



18. Two cylinders each with a height of 50 inches are shown.

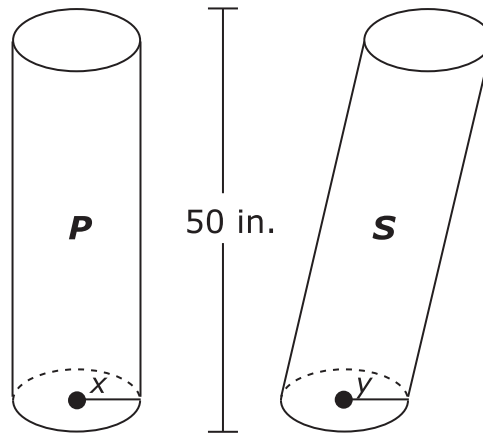

Which statements about cylinders P and S are true?

Select **all** that apply.

- A. If  $x = y$ , the volume of cylinder P is greater than the volume of cylinder S, because cylinder P is a right cylinder.
- B. If  $x = y$ , the volume of cylinder P is equal to the volume of cylinder S, because the cylinders are the same height.
- C. If  $x = y$ , the volume of cylinder P is less than the volume of cylinder S, because cylinder S is slanted.
- D. If  $x < y$ , the area of a horizontal cross section of cylinder P is greater than the area of a horizontal cross section of cylinder S.
- E. If  $x < y$ , the area of a horizontal cross section of cylinder P is equal to the area of a horizontal cross section of cylinder S.
- F. If  $x < y$ , the area of a horizontal cross section of cylinder P is less than the area of a horizontal cross section of cylinder S.



- 19.** Triangle  $ABC$  has vertices at  $A(1, 2)$ ,  $B(4, 6)$ , and  $C(4, 2)$  in the coordinate plane. The triangle will be reflected over the  $x$ -axis and then rotated  $180^\circ$  about the origin to form  $\triangle A'B'C'$ . What are the vertices of  $\triangle A'B'C'$ ?
- A.**  $A'(1, -2)$ ,  $B'(4, -6)$ ,  $C'(4, -2)$
- B.**  $A'(-1, -2)$ ,  $B'(-4, -6)$ ,  $C'(-4, -2)$
- C.**  $A'(-1, 2)$ ,  $B'(-4, 6)$ ,  $C'(-4, 2)$
- D.**  $A'(1, 2)$ ,  $B'(4, 6)$ ,  $C'(4, 2)$



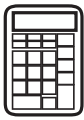

Use the information provided to answer Part A and Part B for question 20.

A steel pipe in the shape of a right circular cylinder is used for drainage under a road. The length of the pipe is 12 feet and its diameter is 36 inches. The pipe is open at both ends.

**20. Part A**

How many square feet of steel is the outer surface of the pipe?

Give your answer to the nearest integer. Enter a number in the answer box.

**Part B**

A wire screen in the shape of a square is attached at one end of the pipe to allow water to flow through but to keep animals from getting inside the pipe. The length of the diagonals of the screen are equal to the diameter of the pipe. The figure represents the placement of the screen at the end of the pipe.

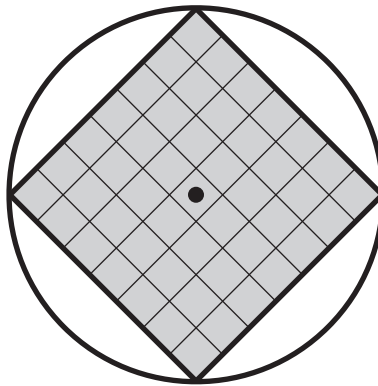

What are the perimeter and area of the screen?

- A.** The perimeter of the screen is approximately 72 inches, and the area of the screen is 324 square inches.
- B.** The perimeter of the screen is approximately 72 inches, and the area of the screen is 648 square inches.
- C.** The perimeter of the screen is approximately 102 inches, and the area of the screen is 648 square inches.
- D.** The perimeter of the screen is approximately 125 inches, and the area of the screen is 1,018 square inches.

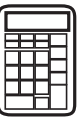

Use the information provided to answer Part A and Part B for question 21.

Triangle  $ABC$  is graphed in the  $xy$ -coordinate plane with vertices  $A(1, 1)$ ,  $B(3, 4)$ , and  $C(-1, 8)$  as shown in the figure.

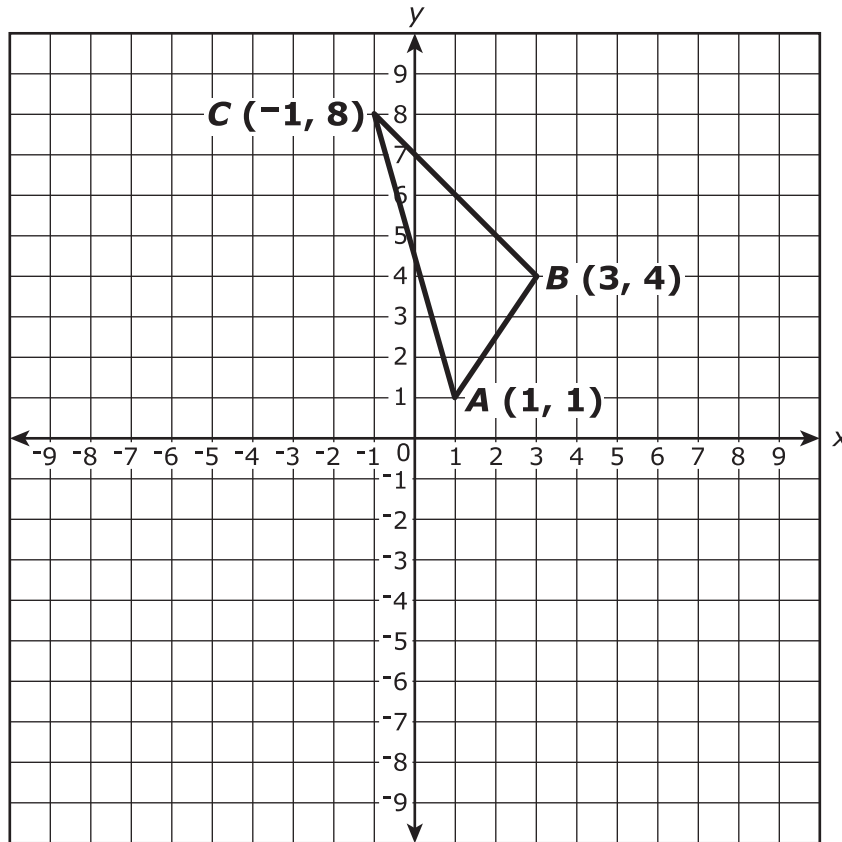

**21. Part A**

Triangle  $ABC$  will be reflected across the line  $y = 1$  to form  $\triangle A'B'C'$ . Which quadrant will **not** contain any vertex of  $\triangle A'B'C'$ ?

- A. First
- B. Second
- C. Third
- D. Fourth



**Part B**

What is the  $y$ -coordinate of  $B'$ ?

Enter your answer in the box.

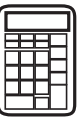

Use the information provided to answer Part A and Part B for question 22.

The figure shows rectangle  $ABCD$  in the coordinate plane with point  $A$  at  $(0, 2.76)$ ,  $B$  at  $(3.87, 2.76)$ ,  $C$  at  $(3.87, 0)$ , and  $D$  at the origin. Rectangle  $ABCD$  can be used to approximate the size of the state of Colorado with the  $x$  and  $y$  scales representing hundreds of miles.

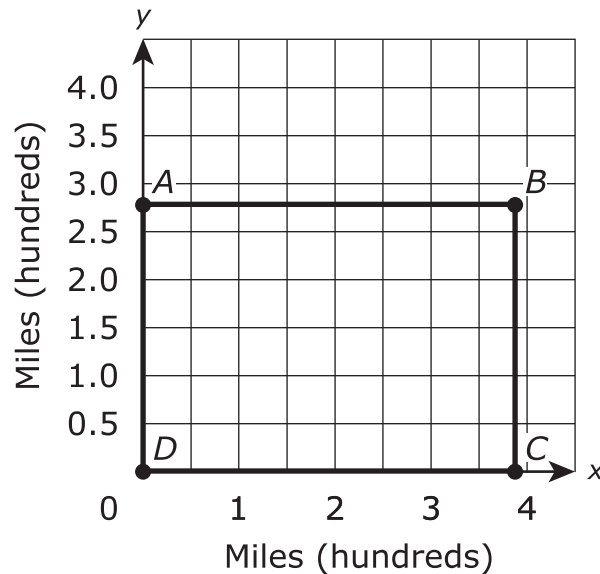

**22. Part A**

Based on the information given, how many miles is the perimeter of Colorado?

Enter your answer in the box.

**Part B**

At the end of 2010, the population of Colorado was 5,029,196 people. Based on the information given, what was the population density at the end of 2010?

- A. 25 people per square mile
- B. 47 people per square mile
- C. 2,269 people per square mile
- D. 7,586 people per square mile

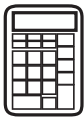

Use the information provided to answer Part A through Part D for question 23.

An unmanned aerial vehicle (UAV) is equipped with cameras used to monitor forest fires. The figure represents a moment in time at which a UAV, at point  $B$ , flying at an altitude of 1,000 meters (m) is directly above point  $D$  on the forest floor. Point  $A$  represents the location of a small fire on the forest floor.

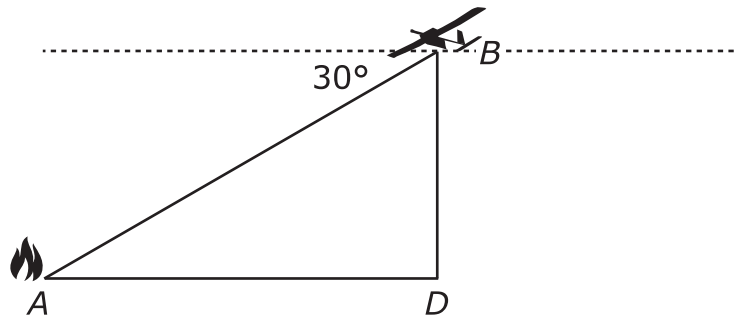

At the moment in time represented by the figure, the angle of depression from the UAV to the fire has a measure of  $30^\circ$ .

**23. Part A**

At the moment in time represented by the figure, what is the distance from the UAV to the fire?

Enter your answer in the box.

**Part B**

What is the distance, to the nearest meter, from the fire to point  $D$ ?

Enter your answer in the box.

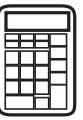

**Part C**

Points  $C$  and  $E$  represent the linear range of view of the camera when it is pointed directly down at point  $D$ .

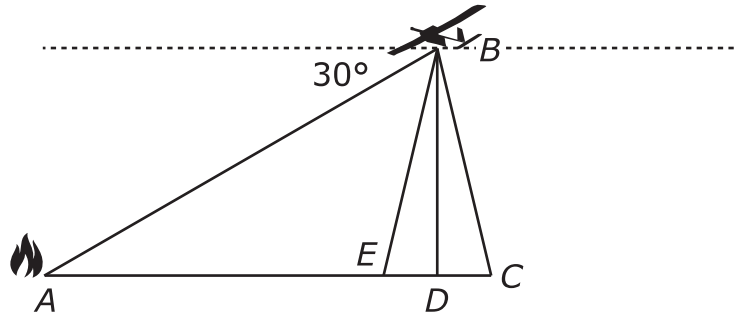

The field of view of the camera is  $20^\circ$  and is represented in the figure by  $\angle CBE$ . If the camera takes a picture directly over point  $D$ , what is the approximate width of the forest floor that will be captured in the picture?

- A. 170 meters
- B. 353 meters
- C. 364 meters
- D. 728 meters

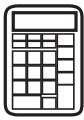
**Part D**

The UAV is flying at a speed of 13 meters per second in the direction toward the fire. Suppose the altitude of the UAV is now 800 meters. The new position is represented at  $F$  in the figure.

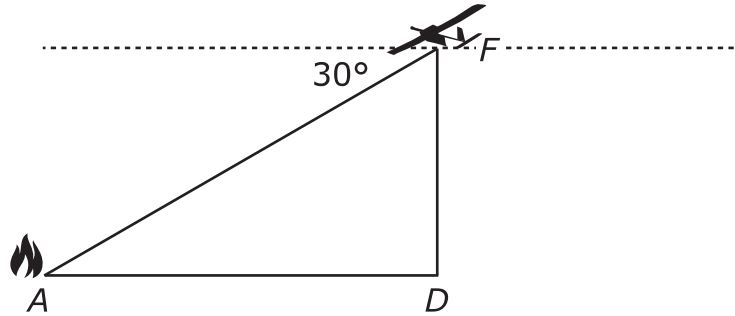

From its position at point  $F$ , how many minutes, to the nearest tenth of a minute, will it take the UAV to be directly over the fire?

- A. 0.6
- B. 1.2
- C. 1.8
- D. 2.0

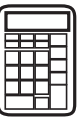

Use the information provided to answer Part A and Part B for question 24.

The figure shows a circle with center  $P$ , a diameter  $\overline{BD}$ , and inscribed  $\triangle BCD$ . The length of  $\overline{PC}$  is 10. Let  $m\angle CBD = (x)^\circ$  and  $m\angle BCD = (x + 54)^\circ$ .

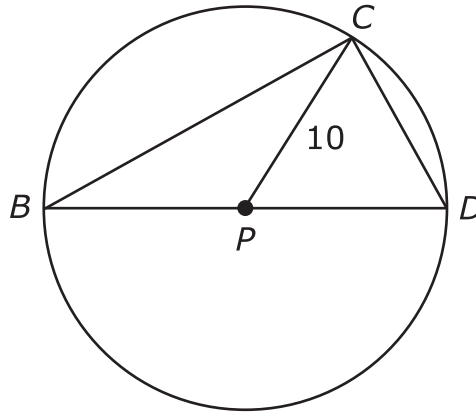

not to scale

**24. Part A**

What is the value of  $x$ ?

Enter your answer in the box.

**Part B**

Identify each of the true statements about the figure.

Select **all** that apply.

- A.** The length of  $\overline{CD}$  is less than 10.
- B.** The length of  $\overline{CD}$  is equal to 10.
- C.** The length of  $\overline{CD}$  is greater than 10.
- D.**  $\triangle CPD$  is equilateral.
- E.** The measure of  $\angle CPD$  is less than  $60^\circ$ .
- F.** The measure of  $\angle CPD$  is greater than  $60^\circ$ .





Use the information provided to answer Part A and Part B for question 25.

The figure shows the result of a geometric construction.

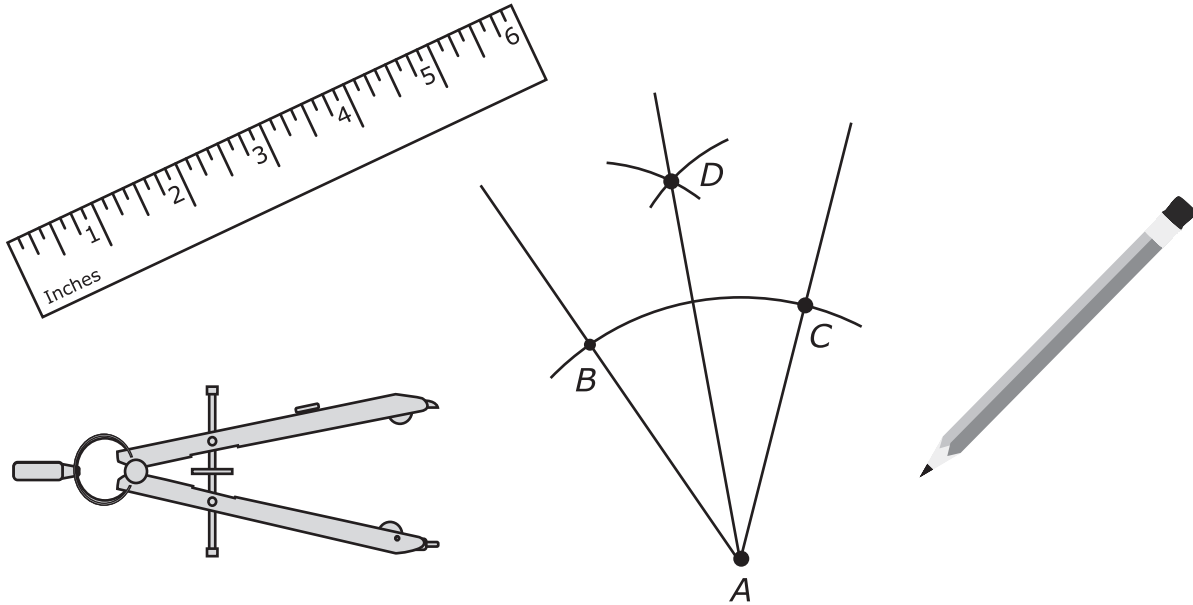

**25. Part A**

The first step of the construction is to draw an arc centered at point  $A$  that passes through point  $B$  and point  $C$ . What is established by the first step?

- A.  $\overline{AB} \cong \overline{BC}$
- B.  $\overline{AB} \cong \overline{AC}$
- C.  $\overline{AD} \cong \overline{AC}$
- D.  $\overline{BD} \cong \overline{CD}$

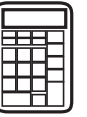
**Part B**

The construction creates congruent triangles.  $\triangle ABD \cong \triangle ACD$  (not shown). Which statement provides evidence that  $\overline{AD}$  is the angle bisector of  $\angle BAC$ ?

- A.  $\angle ACD \cong \angle ABD$
- B.  $\angle BAC \cong \angle BDC$
- C.  $\angle BAD \cong \angle CAD$
- D.  $\angle BAD \cong \angle ABD$

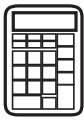

Use the information provided to answer Part A through Part D for question 26.

One method that can be used to prove that the diagonals of a parallelogram bisect each other is shown in the given partial proof.

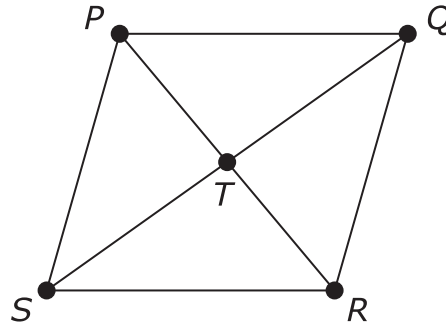

Given: Quadrilateral  $PQRS$  is a parallelogram  
 Prove:  
 $PT = RT$   
 $ST = QT$

Statements	Reasons
1. Quadrilateral $PQRS$ is a parallelogram	1. Given
2. $\overline{PQ} \parallel \overline{SR}$ $\overline{PS} \parallel \overline{QR}$	2. Definition of parallelogram
3. $\angle PQS \cong \angle RSQ$ $\angle QPR \cong \angle SRP$	3. ?
4. ?	4. Opposite sides of a parallelogram are congruent
5. $\triangle SRT \cong \triangle QPT$	5. ?
6. $\overline{PT} \cong \overline{RT}$ $\overline{ST} \cong \overline{QT}$	6. Corresponding parts of congruent triangles are congruent
7. $PT = RT$ $ST = QT$	7. Definition of congruent line segments

**26. Part A**

Which reason justifies the statement for step 3 in the proof?

- A. When two parallel lines are intersected by a transversal, same side interior angles are congruent.
- B. When two parallel lines are intersected by a transversal, alternate interior angles are congruent.
- C. When two parallel lines are intersected by a transversal, same side interior angles are supplementary.
- D. When two parallel lines are intersected by a transversal, alternate interior angles are supplementary.

**Part B**

Which statement is justified by the reason for step 4 in the proof?

- A.  $\overline{PQ} \cong \overline{RS}$
- B.  $\overline{PQ} \cong \overline{SP}$
- C.  $\overline{PT} \cong \overline{TR}$
- D.  $\overline{SQ} \cong \overline{PR}$

**Part C**

Which reason justifies the statement for step 5 in the proof?

- A. side-side-side triangle congruence
- B. side-angle-side triangle congruence
- C. angle-side-angle triangle congruence
- D. angle-angle-side triangle congruence

**Part D**

Another method of proving diagonals of a parallelogram bisect each other uses a coordinate grid.

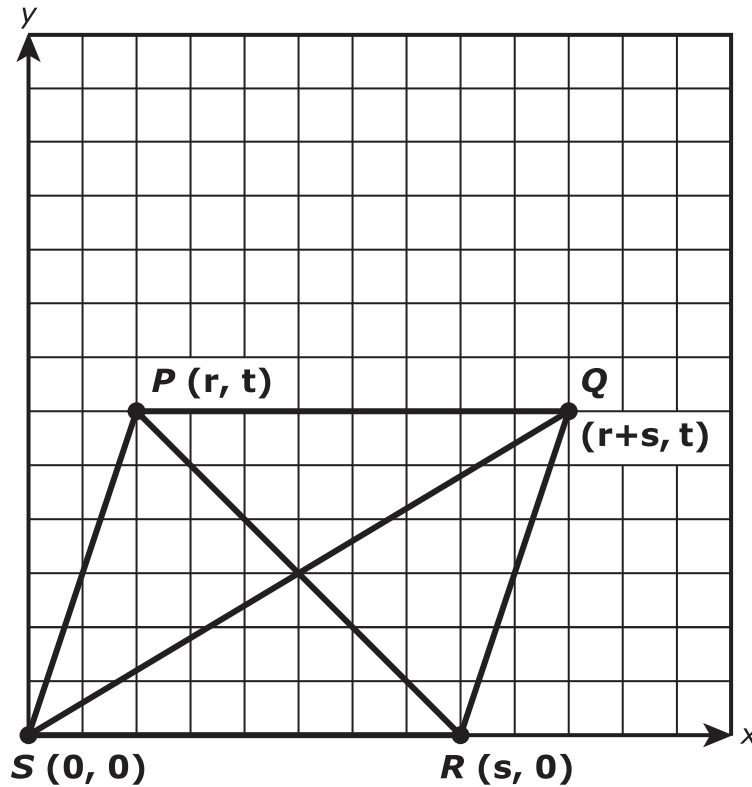

What could be shown about the diagonals of parallelogram  $PQRS$  to complete the proof?

- A.  $\overline{PR}$  and  $\overline{SQ}$  have the same length.
- B.  $\overline{PR}$  is a perpendicular bisector of  $\overline{SQ}$ .
- C.  $\overline{PR}$  and  $\overline{SQ}$  have the same midpoint.
- D. Angles formed by the intersection of  $\overline{PR}$  and  $\overline{SQ}$  each measure  $90^\circ$ .

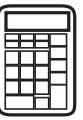

Use the information provided to answer Part A and Part B for question 27.

A spring is attached at one end to support  $B$  and at the other end to collar  $A$ , as represented in the figure. Collar  $A$  slides along the vertical bar between points  $C$  and  $D$ . In the figure, the angle  $\theta$  is the angle created as the collar moves between points  $C$  and  $D$ .

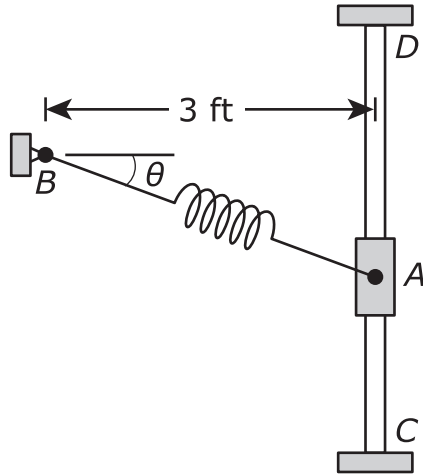

**27. Part A**

When  $\theta = 28^\circ$ , what is the distance from point  $A$  to point  $B$  to the nearest tenth of a foot?

Enter a number in the answer box.

**Part B**

When the spring is stretched and the distance from point  $A$  to point  $B$  is 5.2 feet, what is the value of  $\theta$  to the nearest tenth of a degree?

- A.  $35.2^\circ$
- B.  $45.1^\circ$
- C.  $54.8^\circ$
- D.  $60.0^\circ$



Use the information provided to answer Part A and Part B for question 28.

Quadrilaterals  $ABCD$  and  $EFGH$  are shown in the coordinate plane.

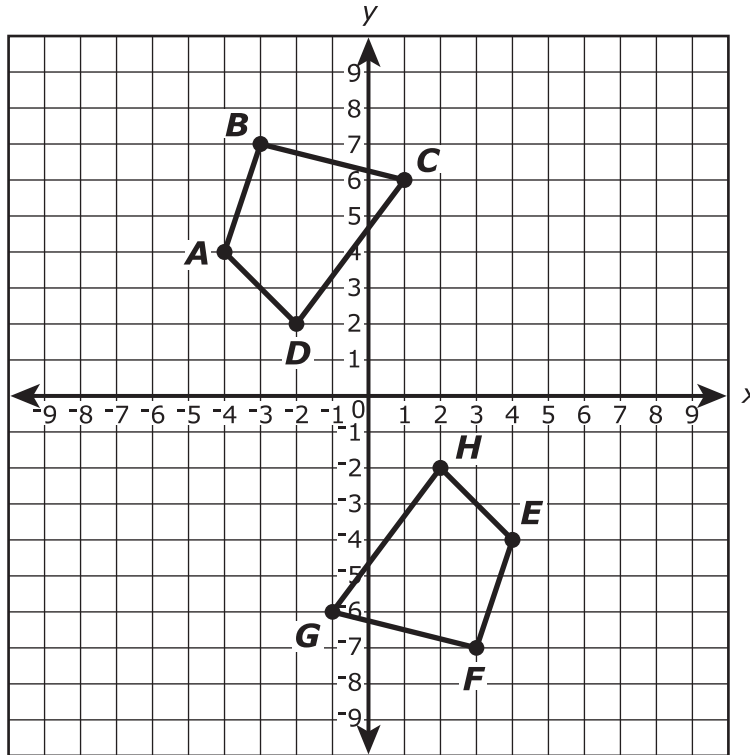

**28. Part A**

Quadrilateral  $EFGH$  is the image of  $ABCD$  after a transformation or sequence of transformations.

Which could be the transformation or sequence of transformations?

Select **all** that apply.

- A.** a translation of 3 units to the right, followed by a reflection across the  $x$ -axis
- B.** a rotation of  $180^\circ$  about the origin
- C.** a translation of 12 units downward, followed by a reflection across the  $y$ -axis
- D.** a reflection across the  $y$ -axis, followed by a reflection across the  $x$ -axis
- E.** a reflection across the line with equation  $y = x$

**Part B**

Quadrilateral  $ABCD$  will be reflected across the  $x$ -axis and then rotated  $90^\circ$  clockwise about the origin to create quadrilateral  $A'B'C'D'$ . What will be the  $y$ -coordinate of  $B'$ ?

Enter your answer in the box.



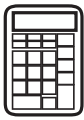

Use the information provided to answer Part A and Part B for question 29.

Point  $B$  is the center of a circle, and  $\overline{AC}$  is a diameter of the circle. Point  $D$  is a point on the circle different from  $A$  and  $C$ .

**29. Part A**

Indicate which statements **must** be true.

Select **all** that apply.

**A.**  $AD > CD$

**B.**  $m\angle CBD = \frac{1}{2}(m\angle CAD)$

**C.**  $m\angle ADC = 90^\circ$

**D.**  $m\angle ABD = 2(m\angle ACD)$

**E.**  $m\angle ABD = m\angle DBC$

**Part B**

If  $m\angle BDA = 20^\circ$ , what is  $m\angle CBD$ ?

**A.**  $20^\circ$

**B.**  $40^\circ$

**C.**  $70^\circ$

**D.**  $140^\circ$



Use the information provided to answer Part A and Part B for question 30.

In the figure shown,  $\overleftrightarrow{CF}$  intersects  $\overleftrightarrow{AD}$  and  $\overleftrightarrow{EH}$  at points  $B$  and  $F$ , respectively.

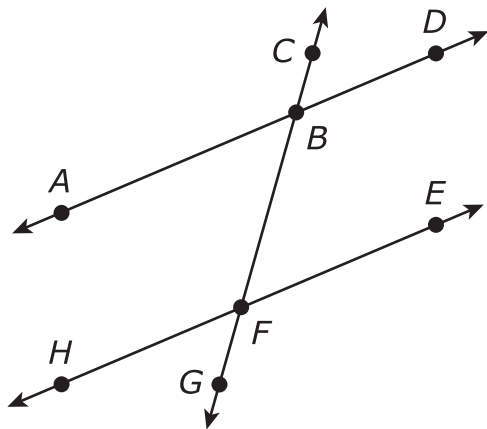

**30. Part A**

- Given:  $\angle CBD \cong \angle BFE$
- Prove:  $\angle ABF \cong \angle BFE$

Statement	Reason
$\angle CBD \cong \angle BFE$	Given
$\angle CBD \cong \angle ABF$	
$\angle ABF \cong \angle BFE$	

Which **two** of the given reasons could be used to correctly complete the proof?

- A.** Definition of congruent angles
- B.** Congruence of angles is reflexive
- C.** Congruence of angles is symmetric
- D.** Congruence of angles is transitive
- E.** Vertical angles are congruent

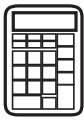
**Part B**

- Given:  $m\angle CBD = m\angle BFE$
- Prove:  $m\angle BFE + m\angle DBF = 180^\circ$

Statement	Reason
$m\angle CBD = m\angle BFE$	Given
$m\angle CBD + m\angle DBF = 180^\circ$	
$m\angle BFE + m\angle DBF = 180^\circ$	

Which **two** of the given reasons could be used to correctly complete the proof?

- A.** Adjacent angles are congruent
- B.** Adjacent angles are supplementary
- C.** Linear pairs of angles are supplementary
- D.** Reflexive property of equality
- E.** Substitution property of equality
- F.** Transitive property of equality

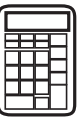

Use the information provided to answer Part A through Part D for question 31.

Luke purchased a warehouse on a plot of land for his business. The figure represents a plan of the land showing the location of the warehouse and parking area. The coordinates represent points on a rectangular grid with units in feet.

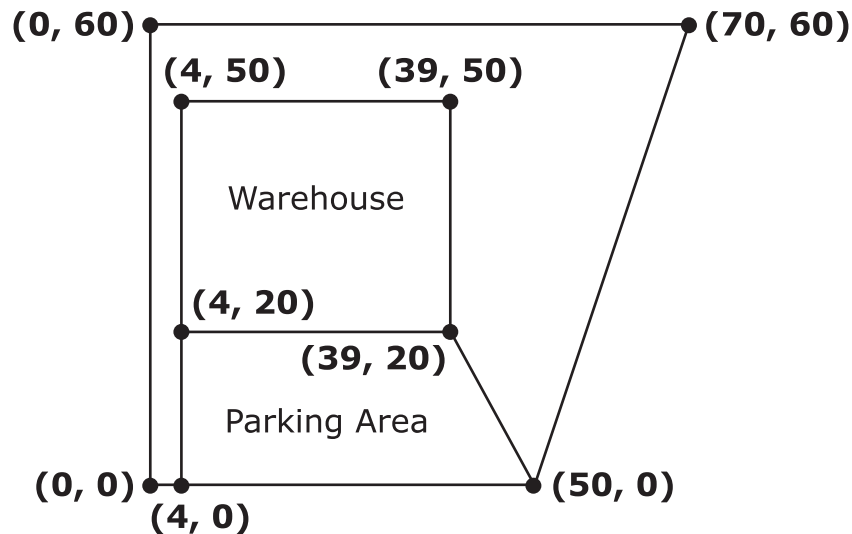

**31. Part A**

What is the perimeter of the plot of land?

Express your answer to the nearest tenth of a foot.

Enter your answer in the box.

**Part B**

What is the area of the plot of land that does **not** include the warehouse and the parking area?

Enter your answer in the box.

**Part C**

Luke is planning to put a fence along two interior sides of the parking area. The sides are represented in the plan by the legs of the trapezoid. What is the total length of fence needed?

Express your answer to the nearest tenth of a foot.

Enter your answer in the box.

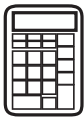
**Part D**

In the future, Luke has plans to construct a circular storage bin centered at coordinates  $(50, 40)$  on the plan. Which of the listed measurements could be the diameter of a bin that will fit on the plot and be **at least** 2 feet away from the warehouse?

Select **all** that apply.

- A. 10 feet
- B. 15 feet
- C. 18 feet
- D. 22 feet
- E. 25 feet

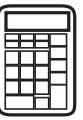

Use the information provided to answer Part A and Part B for question 32.

The figure shows line  $r$ , points  $P$  and  $T$  on line  $r$ , and point  $Q$  not on line  $r$ . Also shown is ray  $PQ$ .

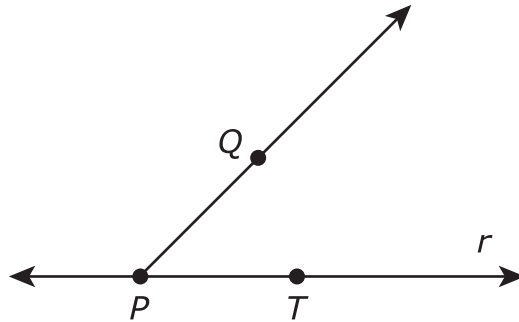

**32. Part A**

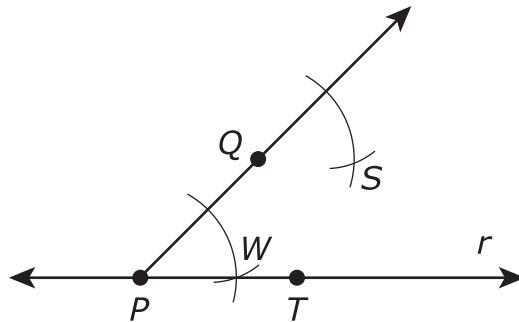

Consider the partial construction of a line parallel to  $r$  through point  $Q$ . What would be the final step in the construction?

- A.** draw a line through  $P$  and  $S$
- B.** draw a line through  $Q$  and  $S$
- C.** draw a line through  $T$  and  $S$
- D.** draw a line through  $W$  and  $S$



**Part B**

Once the construction is complete, which of the reasons listed contribute to proving the validity of the construction?

- A.** When two lines are cut by a transversal and the corresponding angles are congruent, the lines are parallel.
- B.** When two lines are cut by a transversal and the vertical angles are congruent, the lines are parallel.
- C.** Definition of segment bisector
- D.** Definition of an angle bisector





**You have come to the end of the calculator section in Unit 1 of the test.**

- **Review your answers in the calculator section of Unit 1 only.**
- **Then, close your test booklet and answer document and raise your hand to turn in your test materials.**







# GEO

PA0000XXXX